

Kongsberg Maritime is the exclusive distributor of Bergen Engines medium speed engines for commercial marine applications.

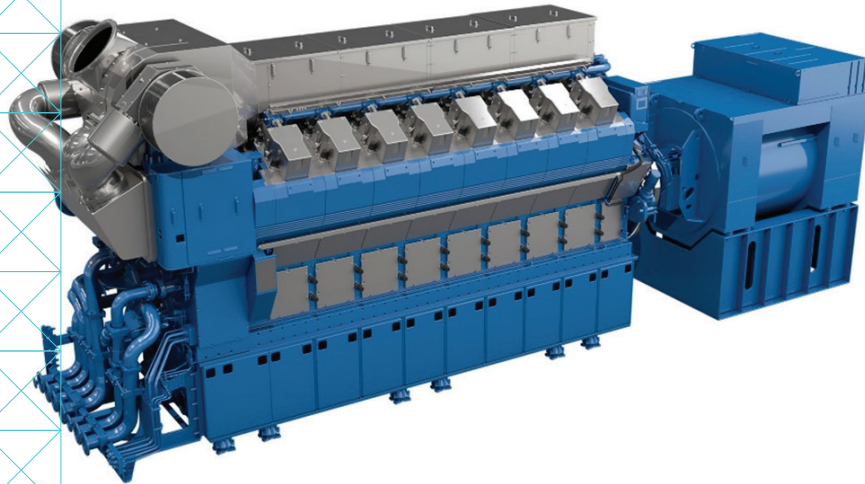

KONGSBERG



MARINE DIESEL ENGINE

Bergen B33:45V generating set

Choose Bergen Engines for cost-effective operation

The Bergen B-series is based on a modular design, which gives a flexible platform and at the same time carries forward the Bergen traditional values as a robust and reliable engine. The selection of technology was done after consulting a broad range of operators, designers and shipbuilders, to establish the qualities they prize in an engine. This engine series was first introduced to the market in 2014 as a diesel engine, and the gas version followed in 2018. It is available in several in-line or Vee cylinder variants for both diesel and gas, and is equally suitable for mechanical transmission or as a marine generating set.

Main benefits for ship yards:

- Easy installation
- New resilient mounting (no need of welding brackets)
- Aligned piping at pump-end for easy connection
- Flexible exhaust routing (and air ducting if applicable): 15 degree rotation of connection points to turbocharger available

Main benefits for ship owners:

- Reliable power
- IMO Tier II compliant without use of SCR
- IMO Tier III compliant with use of SCR
- Proven low life cycle costs
- Dynamic service intervals with 25.000 hrs between main services when operating within a defined load window
- Full equipment health monitoring
- Fast load response
- Low vibration/structural noise level
- 24/7 support by global service network
- Compact and modular design with a low weight construction
- Possible conversion from diesel to gas and vice versa
- New flexible mounts without welded brackets
- Aligned piping at pump end for ease of connection
- Flexible exhaust routing – 15 degree rotation of connections to turbocharger
- Full power can be taken from either end of crankshaft up to and including V12 version

MOST TYPICAL APPLICATIONS

- Subsea construction vessel
- Pipe layer / heavy lift ships
- Seismic survey vessels
- Anchor-handler tug supply vessels
- Fishing vessels
- RoPax
- Ferry
- Cargo ships
- Cruise vessels

TECHNICAL DATA

ENGINE TYPE		B33:45V12A	B33:45V16A
Number of cylinders		12	16
Engine speed	r/min	720/750	720/750
Mean piston speed	m/s	10.8/11.2	10.8/11.2
Max.cont rating (MCR)	kW	7200	9600
Max.cont rating altern, (h=0.975)	kWe1	7020	9360
Max.cont rating altern, (Cos f=0.8)	kVa	8775	11700
Max.cont rating altern, (Cos f=0.9)	kVa	7800	10400
Mean effective pressure (BMEP)	bar	26/25	26/25
Specific fuel oil consumption (SFOC)	g/kWh	from 171	from 171
SFOC with engine driven pumps	g/kWh	from 173	from 173
Specific lubricating oil consumption	g/kWh	0.5	0.5
Cooling water temp. engine outlet	°C	90	90

Engine ratings are according to ISO 3046/1. The above figures are based on conditions at maximum 45°C ambient air temperature and maximum 32°C sea water temperature.

*SFOC is based on MDO with a net calorific value of 42.7 MJ/kg and no engine driven pumps.

Note: Due to continuous development, some data may be changed without notice.

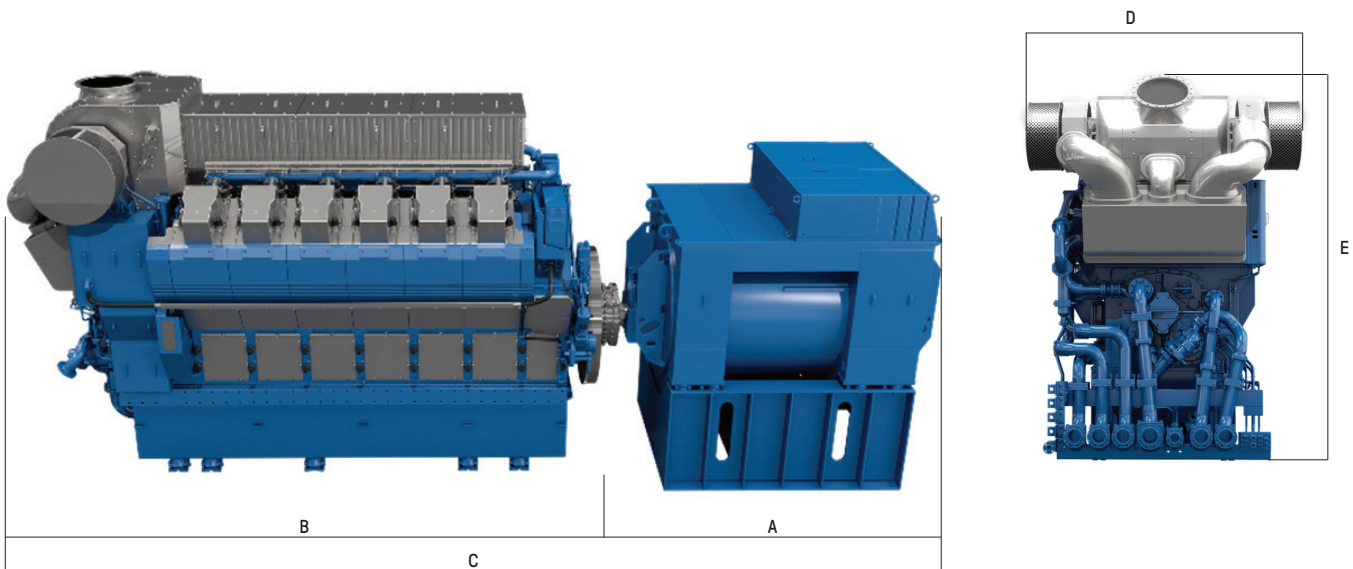

ENGINE TYPE	A	B	C	D	E	WEIGHT DRY ENGINE	WEIGHT GENERATOR
B33:45V12A	3900	6900	10900	3140	4540	74400 kg	25000
B33:45V16A	4500	8400	12900	3660	5010	99700 kg	31000

Weight dry engine excludes generator, foundation and transport foundation.

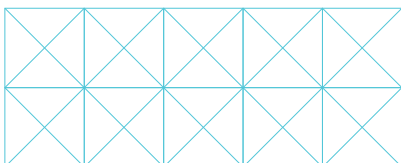

Kongsberg Maritime
P.O.Box 483, NO-3601
Kongsberg, Norway

Switchboard: +47 815 73 700
Global support 24/7: +47 33 03 24 07
E-mail sales: km.sales@km.kongsberg.com
E-mail support: km.support@km.kongsberg.com